

dsc-capstone.org/enrollment

DSC 140B

Representation Learning

Lecture 14 | Part 1

Training Neural Networks

Training

- ▶ How do we learn the weights of a (deep) neural network?

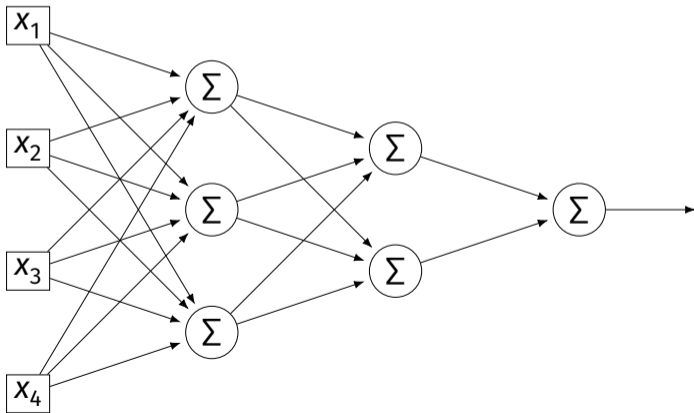

Remember...

- ▶ How did we learn the weights in linear least squares regression?

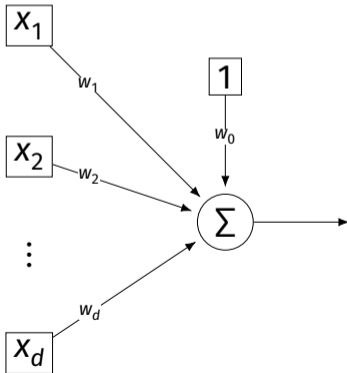

Empirical Risk Minimization

0. Collect a training set, $\{(\vec{x}^{(i)}, y_i)\}$
1. Pick the form of the prediction function, H .
2. Pick a loss function.
3. Minimize the empirical risk w.r.t. that loss.

Remember: Linear Least Squares

0. Pick the form of the prediction function, H .
 - ▶ E.g., linear: $H(\vec{x}; \vec{w}) = w_0 + w_1x_1 + \dots + w_dx_d = \text{Aug}(\vec{x}) \cdot \vec{w}$
1. Pick a loss function.
 - ▶ E.g., the square loss.
2. Minimize the empirical risk w.r.t. that loss:

$$R_{\text{sq}}(\vec{w}) = \frac{1}{n} \sum_{i=1}^n (H(\vec{x}^{(i)}) - y_i)^2 = \frac{1}{n} \sum_{i=1}^n (\text{Aug}(\vec{x}^{(i)}) \cdot \vec{w} - y_i)^2$$

Minimizing Risk

- ▶ To minimize risk, we often use **vector calculus**.
 - ▶ Either set $\nabla_{\vec{w}} R(\vec{w}) = 0$ and solve...
 - ▶ Or use gradient descent: walk in opposite direction of $\nabla_{\vec{w}} R(\vec{w})$.

- ▶ Recall, $\nabla_{\vec{w}} R(\vec{w}) = (\partial R / \partial w_0, \partial R / \partial w_1, \dots, \partial R / \partial w_d)^T$

In General

- ▶ Let ℓ be the loss function, let $H(\vec{x}; \vec{w})$ be the prediction function.
- ▶ The empirical risk:

$$R(\vec{w}) = \frac{1}{n} \sum_{i=1}^n \ell(H(\vec{x}^{(i)}; \vec{w}), y_i)$$

- ▶ Using the chain rule:

$$\nabla_{\vec{w}} R(\vec{w}) = \frac{1}{n} \sum_{i=1}^n \frac{\partial \ell}{\partial H} \nabla_{\vec{w}} H(\vec{x}^{(i)}; \vec{w})$$

Gradient of H

- ▶ To minimize risk, we want to compute $\nabla_{\vec{w}} R$.
- ▶ To compute $\nabla_{\vec{w}} R$, we want to compute $\nabla_{\vec{w}} H$.
- ▶ This will depend on the form of H .

Example: Linear Model

- ▶ Suppose H is a linear prediction function:

$$H(\vec{x}; \vec{w}) = w_0 + w_1 x_1 + \dots + w_d x_d$$

- ▶ What is $\nabla_{\vec{w}} H$ with respect to \vec{w} ?

Example: Linear Model

- ▶ Consider $\partial H / \partial w_1$:

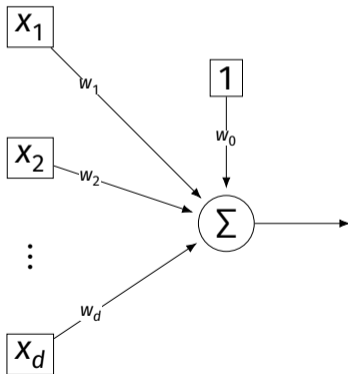

Example: Neural Networks

- ▶ Suppose H is a neural network (with nonlinear activations).
- ▶ What is ∇H ?
 - ▶ It's more complicated...

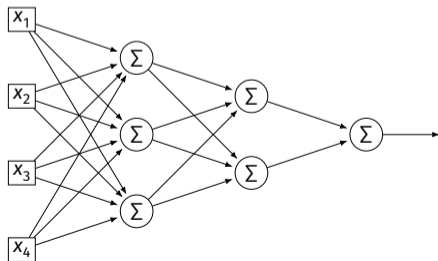

Parameter Vectors

- ▶ It is often useful to pack all of the network's weights into a **parameter vector**, \vec{w} .
- ▶ Order is arbitrary:

$$\vec{w} = (W_{11}^{(1)}, W_{12}^{(1)}, \dots, b_1^{(1)}, b_2^{(1)}, W_{11}^{(2)}, W_{12}^{(2)}, \dots, b_1^{(2)}, b_2^{(2)}, \dots)^T$$

- ▶ The network is a function $H(\vec{x}; \vec{w})$.
- ▶ Goal of learning: find the “best” \vec{w} .

Gradient of Neural Network

- ▶ $\nabla_{\vec{w}} H$ is a vector-valued function.
- ▶ Plugging a data point, \vec{x} , and a parameter vector, \vec{w} , into $\nabla_{\vec{w}} H$ “evaluates the gradient”, results in a vector, same size as \vec{w} .

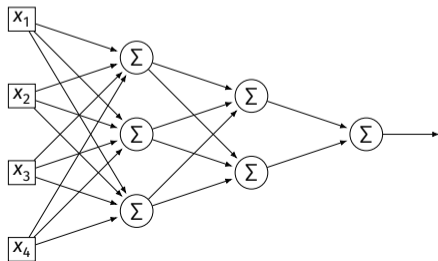

Exercise

Suppose $W_{11}^{(1)} = -2, W_{21}^{(1)} = -5, W_{31}^{(1)} = 2$ and $\vec{x} = (3, 2, -2)^T$ and all biases are 0. ReLU activations are used. What is $\partial H / \partial W_{11}^{(1)}(\vec{x}, \vec{w})$?

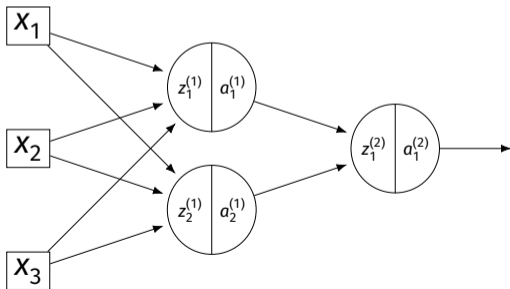

Example

- ▶ Consider $\partial H / \partial W_{11}^{(3)}$:

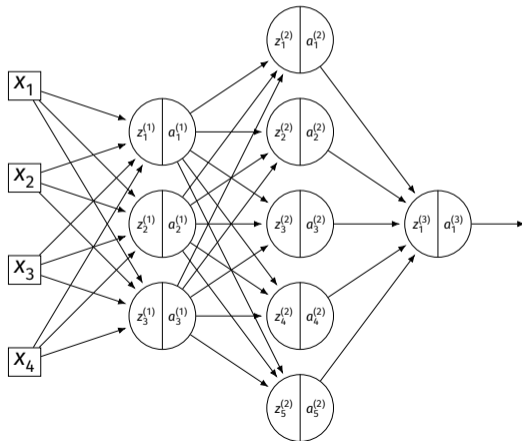

Example

- ▶ Consider $\partial H / \partial W_{11}^{(2)}$:

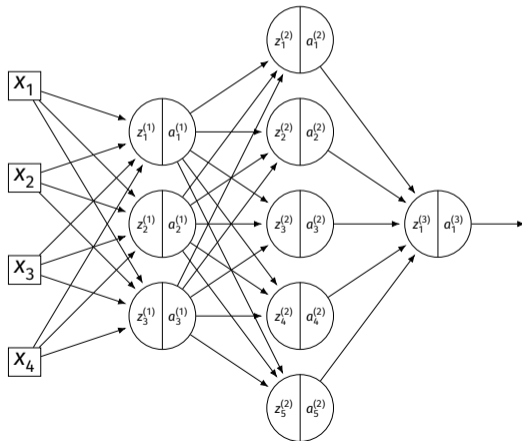

Example

- ▶ Consider $\partial H / \partial W_{11}^{(1)}$:

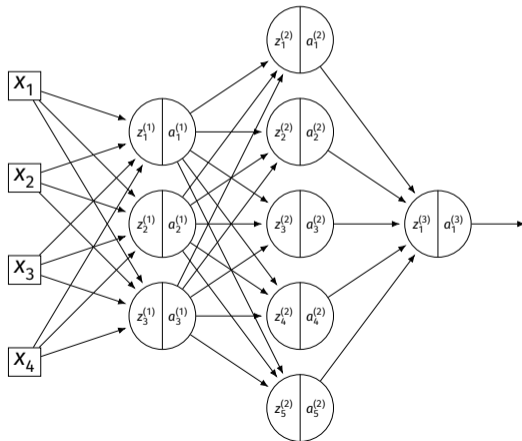

A Better Way

- ▶ Computing the gradient is straightforward...
- ▶ But can involve a lot of repeated work.
- ▶ **Backpropagation** is an algorithm for efficiently computing the gradient of a neural network.

DSC 140B

Representation Learning

Lecture 14 | Part 2

Backpropagation

Gradient of a Network

- ▶ We want to compute the gradient $\nabla_{\vec{w}} H$.
 - ▶ That is, $\partial H / \partial W_{ij}^{(\ell)}$ and $\partial H / \partial b_i^{(\ell)}$ for all valid i, j, ℓ .
- ▶ A network is a composition of functions.
- ▶ We'll make good use of the **chain rule**.

Recall: The Chain Rule

$$\begin{aligned}\frac{d}{dx}f(g(x)) &= \frac{df}{dg} \frac{dg}{dx} \\ &= f'(g(x))g'(x)\end{aligned}$$

Some Notation

- ▶ We'll consider an arbitrary node in layer ℓ of a neural network.
- ▶ Let g be the activation function.
- ▶ n_ℓ denotes the number of nodes in layer ℓ .

Arbitrary Node

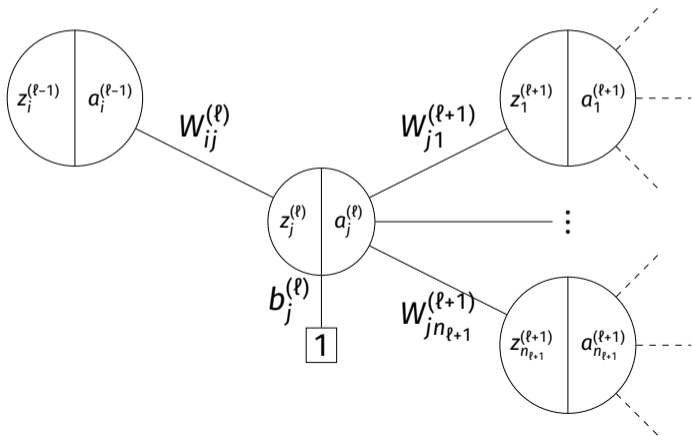

► $\frac{\partial H}{\partial W_{ij}^{(\ell)}}$?

► $\frac{\partial H}{\partial b_j^{(\ell)}}$?

Claim #1

$$\frac{\partial H}{\partial W_{ij}^{(\ell)}} = \frac{\partial H}{\partial z_j^{(\ell)}} a_i^{(\ell-1)}$$

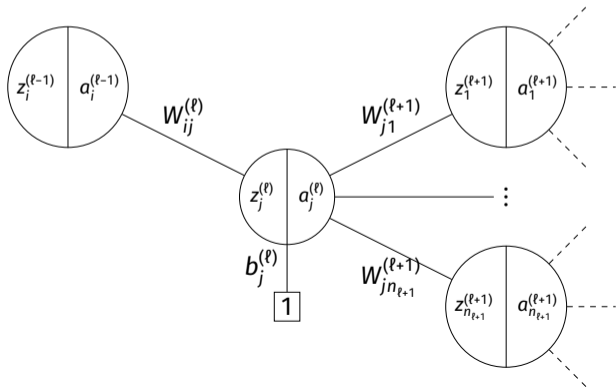

Claim #2

$$\frac{\partial H}{\partial z_j^{(\ell)}} = \frac{\partial H}{\partial a_j^{(\ell)}} g'(z_j^\ell)$$

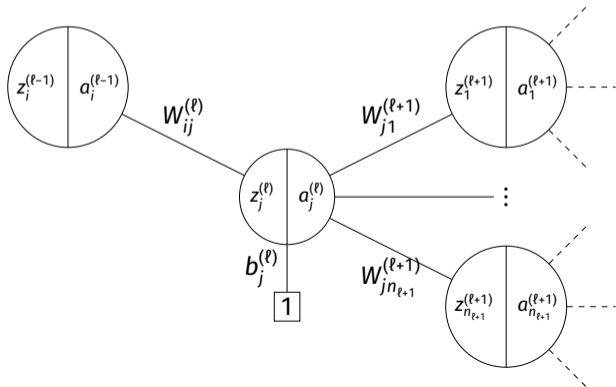

Claim #3

$$\frac{\partial H}{\partial a_j^{(\ell)}} = \sum_{k=1}^{n_{\ell+1}} \frac{\partial H}{\partial z_k^{(\ell+1)}} W_{jk}^{(\ell+1)}$$

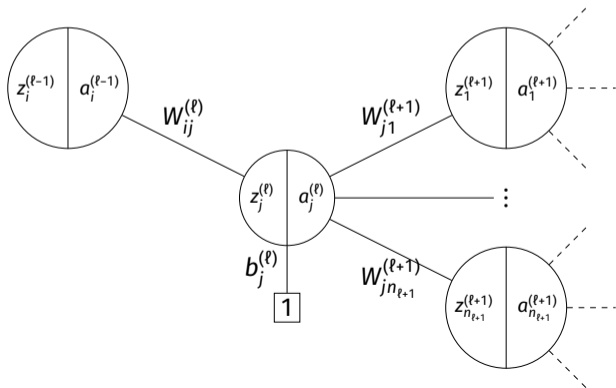

Exercise

What is $\partial H / \partial b_j^{(\ell)}$?

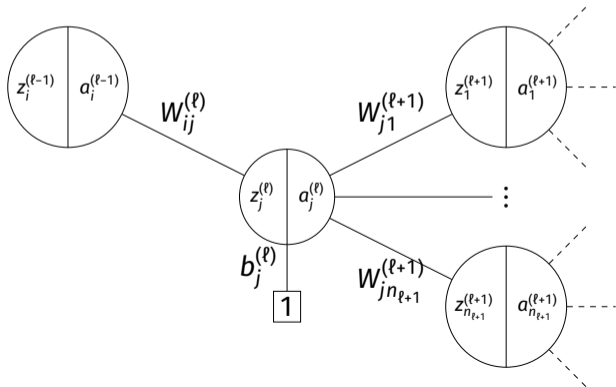

General Formulas

- ▶ For any node in any neural network¹, we have the following recursive formulas:

- ▶
$$\frac{\partial H}{\partial a_j^{(\ell)}} = \sum_{k=1}^{n_{\ell+1}} \frac{\partial H}{\partial z_k^{(\ell+1)}} W_{jk}^{(\ell+1)}$$

- ▶
$$\frac{\partial H}{\partial z_j^{(\ell)}} = \frac{\partial H}{\partial a_j^{(\ell)}} g'(z_j^{(\ell)})$$

- ▶
$$\frac{\partial H}{\partial W_{ij}^{(\ell)}} = \frac{\partial H}{\partial z_j^{(\ell)}} a_i^{(\ell-1)}$$

- ▶
$$\frac{\partial H}{\partial b_j^{(\ell)}} = \frac{\partial H}{\partial z_j^{(\ell)}}$$

¹Fully-connected, feedforward network

Main Idea

The derivatives in layer ℓ depend on derivatives in layer $\ell + 1$.

Backpropagation

- ▶ **Idea:** compute the derivatives in last layers, first.
- ▶ That is:
 - ▶ Compute derivatives in last layer, ℓ ; store them.
 - ▶ Use to compute derivatives in layer $\ell - 1$.
 - ▶ Use to compute derivatives in layer $\ell - 2$.
 - ▶ ...

Backpropagation

Given an input \vec{x} and a current parameter vector \vec{w} :

1. Evaluate the network to compute $z_j^{(\ell)}$ and $a_j^{(\ell)}$ for all nodes.
2. For each layer ℓ from last to first:

▶ Compute $\frac{\partial H}{\partial a_j^{(\ell)}} = \sum_{k=1}^{n_{\ell+1}} \frac{\partial H}{\partial z_k^{(\ell+1)}} W_{jk}^{(\ell+1)}$

▶ Compute $\frac{\partial H}{\partial z_j^{(\ell)}} = \frac{\partial H}{\partial a_j^{(\ell)}} g'(z_j^{(\ell)})$

▶ Compute $\frac{\partial H}{\partial W_{ij}^{(\ell)}} = \frac{\partial H}{\partial z_j^{(\ell)}} a_i^{(\ell-1)}$

▶ Compute $\frac{\partial H}{\partial b_j^{(\ell)}} = \frac{\partial H}{\partial z_j^{(\ell)}}$

Example

Compute the entries of the gradient given:

$$W^{(1)} = \begin{pmatrix} 2 & -3 \\ 2 & 1 \end{pmatrix} \quad W^{(2)} = \begin{pmatrix} 2 & 1 \\ 0 & 1 \end{pmatrix} \quad W^{(3)} = \begin{pmatrix} 3 \\ -2 \end{pmatrix} \quad \vec{x} = (2, 1)^T \quad g(z) = \text{ReLU}$$

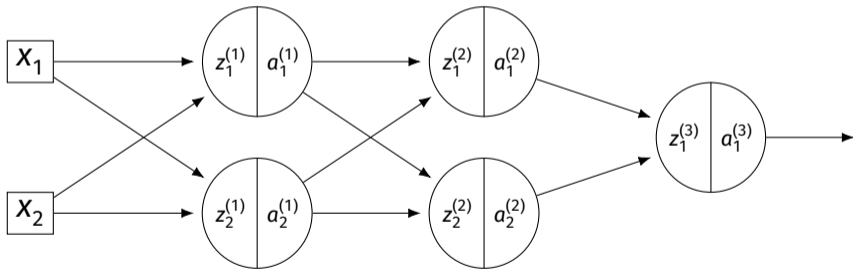

$$\frac{\partial H}{\partial a_j^{(\ell)}} = \sum_{k=1}^{n_{\ell+1}} \frac{\partial H}{\partial z_k^{(\ell+1)}} W_{jk}^{(\ell+1)} \quad \frac{\partial H}{\partial z_j^{(\ell)}} = \frac{\partial H}{\partial a_j^{(\ell)}} g'(z_j^{(\ell)}) \quad \frac{\partial H}{\partial W_{ij}^{(\ell)}} = \frac{\partial H}{\partial z_j^{(\ell)}} a_i^{(\ell-1)}$$

Aside: Derivative of ReLU

$$g(z) = \max\{0, z\}$$

$$g'(z) = \begin{cases} 0, & z < 0 \\ 1, & z > 0 \end{cases}$$

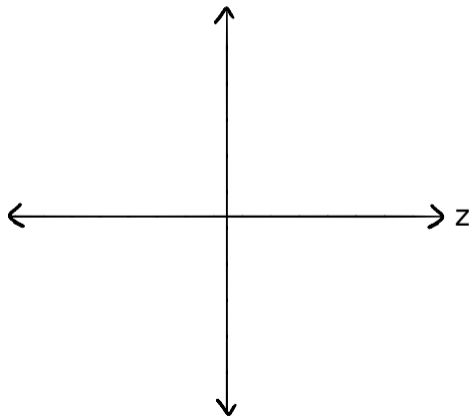

Summary: Backprop

- ▶ **Backprop** is an algorithm for efficiently computing the gradient of a neural network
- ▶ It is not an algorithm **you** need to carry out by hand: your NN library can do it for you.